



单节 4A 高压输入快速充电/放电二合一 IC

产品概述

VAS5289 是一款适用于单节锂离子电池和锂聚合物电池的宽输入与输出电压范围的开关型充电管理与升压转换器的二合一 IC，该器件支持 15V 高输入电压快速充电，1.0MHz 同步降压转换器支持最大充电电流达 4.0A；升压转换器采用同步整流工作在 600KHz，具有 2.8V 至 4.5V 输入电压范围依输出功率选择外置功率 MOS，实现高放电效率，具备 10A 开关电流能力，并且能够提供高达 12.6V 的输出电压。其应用时仅需极少的外围器件，有效降低 BOM 成本，可编程电池电压可以匹配不同形态的电芯达到电量的优化，电池放电时电压低电与过温保护，输出过流/短路保护等电路，确保芯片和系统安全工作。内部集成升压电阻网路，透过 VOST1,2 可直接与 CHY-100 输出控制匹配做 5V/9V/12V 的输出切换，亦提共反馈引脚，支持外部电阻网路控制输出电压，可匹配 QC3.0 每 200mV 步阶输出，不受各式协议限制，可适应各种快充握手协议的辨识芯片完成输出电压的切换。具体该单芯片二合一设计解决 QC IN/OUT 核心电源管理。

充电特点

- 4.5~15V 输入
- 充电电流 1.8A/ 2.25A/ 2.7A
- 4A 充电高达 92%效率
- 高电压输入(9V/12V) 进行了 1.5X 快充优化
- 涓流，恒流，恒压和满充指示管理
- 1.0MHz 开关频率，支持 1.5uH 电感
- 支持 4.20V/ 4.30V/ 4.35V 电池
- 1.5hr 背景尾电流充电
- 两阶自适应充电管理(VCC-DPM)
- 5V 输入支持边充边放
- 异常报错显示
- 多重保护:
 - 电池短路与电池过压保护(BOVP)
 - 电池温度检测(50°C)

升压特点

- 小于 30uA 电池存放漏电流
- 600KHz 开关频率，共享电感 (1.5 uH)
- 外置 MOS，支持 9V/2A, 12V/1.5A 输出
- 最大支持 25W 输出
- 高达 92%效率
- 电池电压 2.80V 以下自动关闭输出
- 快速动态响应，支持全陶瓷电容应用
- 5V/ 9V/ 12V，可符合 QC2.0
- 200mV 步阶升压，可符合 QC3.0
- 支持外部电阻做线性调控输出(5V~12.6V)
- 过电流以 CC 模式输出，恒功率点可调
- 多重保护:
 - 过电流限流输出/短路保护
 - 过载自动降率为 5V 输出
 - 低电压 3.1V 自动调节为 5V 输出
 - 快充指令脱离时，自动调节为 5V 输出
 - 升压关机或异常关闭时，输出高压自动泄放，断开输出
 - 驱动外接 N 沟道 MOSFET 可完全断开 USB-A 口
 - 电池温度检测(60°C)

应用领域

- 移动电源(QC2.0/3.0,PD1.0)
- 无线蓝牙音箱
- 便携式网络设备

封装

- TQFN4x4-24



Typical Application Circuits

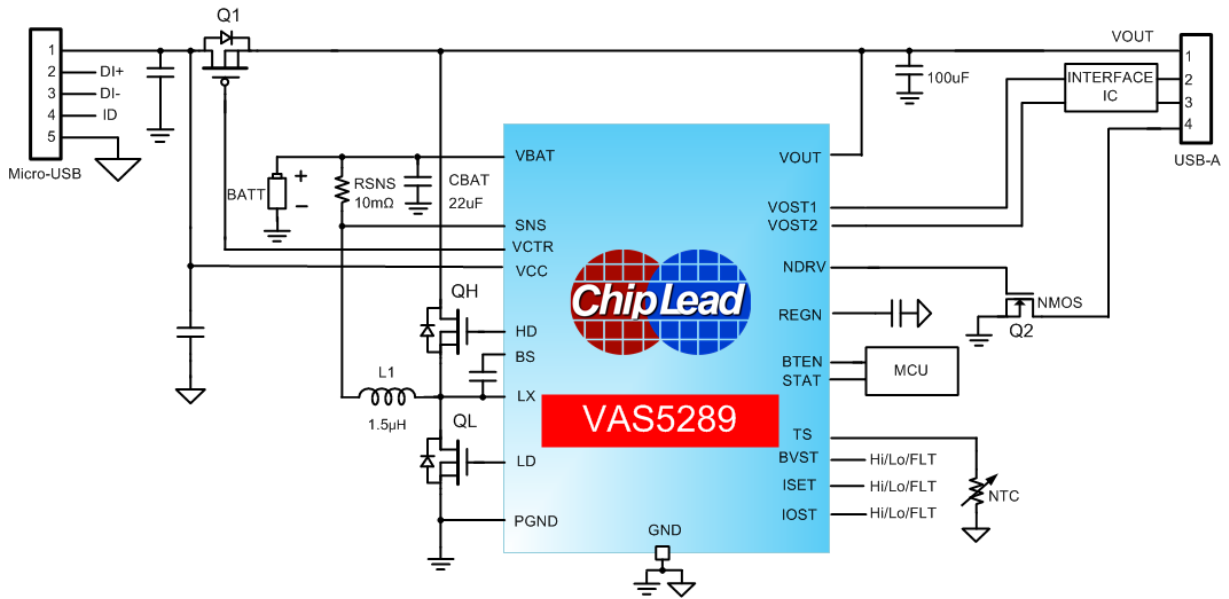

Figure1. Typical Application Schematic with CHY-100 Compatible Interface IC

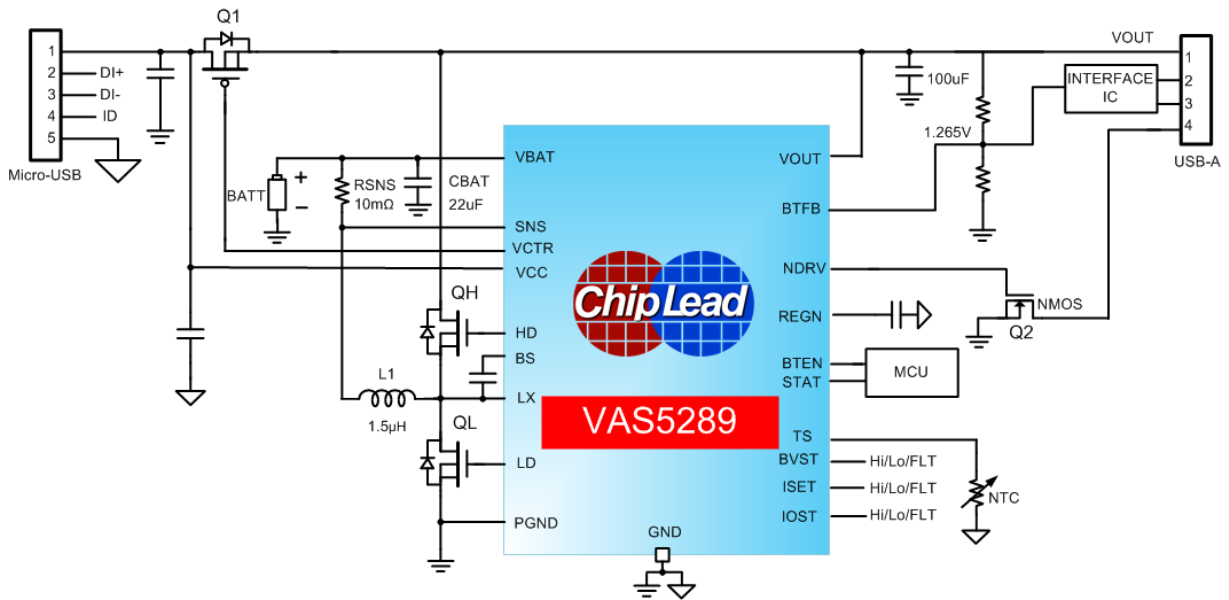
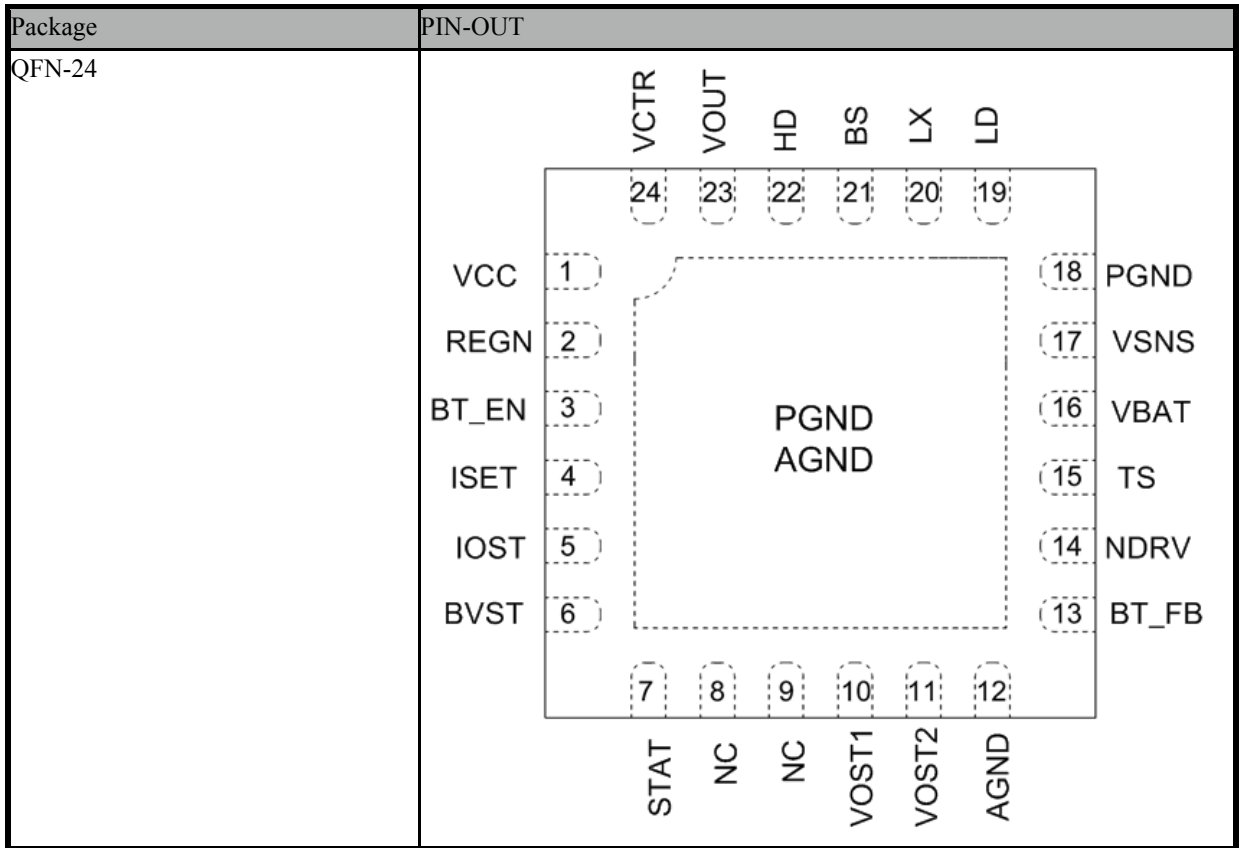

Figure 2. Typical Application Schematic Using Ext. Resistor Network



PIN Configuration





PIN Description

TQFN PIN NO.	Name	Description			
1	VCC	USB 或 AC 适配器输入。当 VCC 存在时，充电和电源管理路径工作，使用 10uF 陶瓷电容连接 VCC 与 PGND。			
2	REGN	5V 电源输出，通过一个 4.7uF 陶瓷电容旁路到地。			
3	BT_EN	BOOST MODE 使能引脚，高电平启动。			
4	ISET	快充电流设置，设置VSNS与VBAT之间的采样量以控制快充电流。 Lo: 18mV / FLT: 22.5mV / Hi: 27mV			
5	IOST	升压恒流点设置。设置VBAT与VSNS之间的采样量以控制升压恒流点。 Lo: 50mV / FLT: 75mV / Hi: 100mV			
6	BVST	恒压电压设置。 Lo: 4.30V / FLT: 4.20V / Hi: 4.35V			
7	STAT	状态指示(Open drain)			
		Hi-Z	Low	Blinking	
		充电完成或休眠模式	充电中	异常	
8,9	NC	无连接。			
10, 11	VOST1-2	输出电压设置引脚 1,2。(VOTST1/VOST2 状态如下)			
		FLT / FLT	LO / FLT	LO / LO	FLT / LO
		5V OUT	9V OUT	12V OUT	Ext. Resistor
12	AGND	模拟地。			
13	BT_FB	输出电压反馈输入脚。 VOST1=FLT, VOST2=LO, 使用外部电阻调控 BOOST 电压。			
14	NDRV	驱动外接 N 沟道 MOSFET 进行短路和漏电保护。升压启动 NDRV 为高电平，VOUT 电压过高过低或者过流检测发生时，NDRV 转低电平。待机时，NDRV 维持低电平。			
15	TS	电池温度采样端口，连接到电池温度调节器端子(TS)，如果不连接到电池，可以连接至地以屏蔽TS功能。推荐选料10K TS (B-Constant=3950K)。			
16	VBAT	电池输入与充电恒压调节端口。电感连接至电池的正级需使用22uF低ESR和ESL陶瓷电容旁路到地。			
17	VSNS	充电电流与放电过流采样输入。通过 RSNS 电阻检测充放电电流。			
18	PGND	功率地。连接内部低端 MOSFET 驱动地。			
19	LD	低端 MOSFET 驱动输出。			
20	LX	外部开关与电感的连接端口，高端 MOSFET 驱动地。			
21	BS	Bootstrap 引脚输入，使用 22-47nF 陶瓷电容连接 LX 与 BS。 **建议接一个 1N4148 由 REGN 给 BS pin 供电加速 BS 电容充电。			
22	HD	高端 MOSFET 驱动输出。			
23	VOUT	输出端口。通过低 ESR 和 ESL 陶瓷电容旁路到地，电容 44uF~470uF 可以稳定。			
24	VCTR	驱动外接P沟道MOSFET防止反向电流。电源输入时，VCTR为低电平，电源移除时，VCTR为高电平。			
25	EP	底部焊盘。连接到 PCB 的地。			



Order Information

Order Number	Package Type	QTY/Reel	Green Status	Operation temp range
VAS5289IJ24E	QFN24	2500	RoHS	-40 °C to 85°C

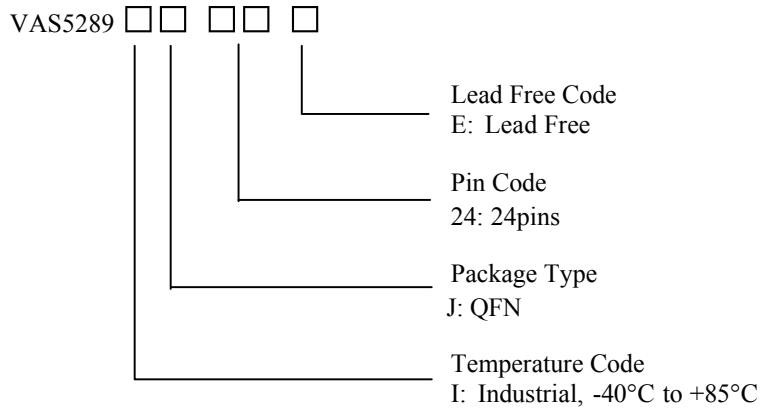

Absolute Maximum Ratings

Parameters	Maximum Ratings
VCC, VCTR, VOUT, STAT	-0.3V to 20V
LX	-2V to 15V
REGN, VBAT, BT_EN, NDRV, VSNS ISET, BVST, IOST, TS, LD	-0.3V to 7V
VOST1, VOST2	-0.3V to 15V
HD, BS	-0.3V to 20V
GND, PGND	-0.3V to +0.3V
Junction temperature range	-40°C to +150°C
Storage temperature range	-65°C to +150°C
Lead Temperature	260°C
Maximum Power Dissipation	2W
ESD (HBM)	2000V



Electrical Characteristics

PARAMETERS		TEST CONDITIONS	MIN	TYP	MAX	UNITS
OPERATING CONDITIONS						
V _{VCC_OP}	VCC input voltage operating range during charging.		4.5		15	V
QUIESCENT CURRENT						
I _{IN}	Adapter supply current	VCC=5V		1.5	2	mA
I _{BAT}	Battery discharge current	V _{BAT} =4.2V, standby mode		40	60	μA
CHARGE VOLTAGE REGULATION						
V _{BAT_REG}	BAT regulation voltage	Measured on BAT		4.2		V
	Charge voltage regulation accuracy	TJ = -20°C to 85°C	-1%		1%	
V _{BAT_ADJ}	Regulation voltage Adjustment	BVST=FLT,		4.20		V
		BVST=Lo		4.30		V
		BVST=Hi		4.35		V
CURRENT REGULATION						
I _{CHG}	Fast charge current	Programmable Mode(Max)		2.7		A
	Charge current regulation accuracy	TJ = -20°C to 85°C	-10%		10%	
V _{VSNS-VBAT}	Charge Current Full Scale Sense Voltage	ISET=FLT, RSNS=10mΩ		22.5		mV
		ISET=Lo, RSNS=10mΩ		18		mV
		ISET=Hi, RSNS=10mΩ		27		mV
	Output “fast charge” formula	$V_{BAT_REG} > V_{BAT} > V_{LOWV}$;	$V_{VSNS-VBAT} / RSNS$			A
% _{QUICK_CHG}	Quick-charge current	VCC>7.5V		150		% _{ICHG-CC}
V _{C_{CC}_DPM1}	Input voltage drop to reduce charge current	VCC < 7.5V, Measured on VCC		4.60		V
V _{C_{CC}_DPM1}	Input voltage drop to reduce charge current	VCC > 7.5V Measured on VCC		8.30		V
CURRENT REGULATION –PRE- CHARGE						
% _{PRECHG}	Pre-charge current, default setting	V _{BAT} < V _{LOWV}		10		% _{ICHG-CC}
CHARGE TERMINATION						
% _{TERM}	Termination threshold current, default setting	V _{BAT} > V _{RECHG}	5	10	15	% _{ICHG-CC}
t _{TERM_DEG}	Deglintch time termination (both edges)	V _{BAT} > V _{RECHG} and I _{CHG} < I _{TERM}		100		ms
BAT LOWV COMPARATOR						
V _{LOWV}	Precharge to fast charge transition threshold	Measured on BAT	2.90	2.95	3.00	V
RECHARGE COMPARATOR						
V _{RECHG}	Recharge threshold, V _{BAT_REG} -V _{BAT}	Measured on BAT	75	100	150	mV



PARAMETERS	TEST CONDITIONS	MIN	TYP	MAX	UNITS	
BAT OVER-VOLTAGE COMPARATOR						
V_{BOV_RISE}	Battery over-voltage rising threshold	As percentage of V_{BAT_REG}	110		%	
V_{BOV_FALL}	Battery over-voltage falling threshold	As percentage of V_{BAT_REG}	105		%	
BAT SHORT COMPARATOR						
V_{BSHORT_RISE}	Battery short hysteresis	V_{BAT} rising	2.4	2.5	V	
V_{BSHORT_FALL}	Battery short threshold	V_{BAT} falling	2.0	2.2	V	
I_{BSHORT}	Battery short weakly pull high current	$V_{BAT} < V_{BSHORT}$, measure I_{BAT}	10	15	20	mA
INPUT OVER-VOLTAGE COMPARATOR (ACOV)						
V_{ACOV}	AC over-voltage rising threshold to disable charge	VCC rising	16.0	16.8	17.4	V
V_{ACOV_HYS}	AC over-voltage falling hysteresis	VCC falling		500		mV
INPUT UNDER-VOLTAGE LOCK-OUT COMPARATOR (UVLO)						
V_{UVLO}	AC under-voltage rising	Measure on VCC		4.0		V
V_{UVLO_HYS}	AC under-voltage hysteresis	Measure on VCC		300		mV
SLEEP COMPARATOR(REVERSE DISCHARGING PROTECTION)						
V_{SLEEP}	SLEEP mode threshold	$VCC - V_{BAT}$ falling		100		mV
V_{SLEEP_HYS}	SLEEP mode hysteresis	$VCC - V_{BAT}$ rising		200		mV
$V_{BT_EN_LO}$	VBT_EN output low voltage	$VCC < V_{BAT} + V_{SLEEP}$			0.1	V
$V_{BT_EN_HI}$	VBT_EN output high voltage	$VCC > V_{BAT} + V_{SLEEP_HYS}$	VOUT -0.1			V
THERMISTOR COMPARATOR						
I_{TS}	TS bias current		72	80	88	μA
V_{LTF}	Cold temperature threshold, TS pin voltage rising threshold	Charger suspends charge		3.0		V
V_{LTF_HYS}	Cold temperature hysteresis, TS pin voltage falling threshold	Charger recovery charge		2.6		V
V_{HTF}	Hot temperature TS pin voltage falling threshold	Charger suspends charge		300		mV
V_{HTF_HYS}	Hot temperature hysteresis, TS pin voltage rising threshold	Charger recovery charge		400		mV



PARAMETERS		TEST CONDITIONS	MIN	TYP	MAX	UNITS
V_{BT_HTF}	Boost mode, hot temperature TS pin voltage falling threshold	Booster suspends output		200		mV
$V_{BT_HTF_HYS}$	Boost mode, hot temperature hysteresis, TS pin voltage rising threshold	Booster recovery output		300		mV
$V_{TS_DISABLE}$	Disable TS pin threshold	$V_{TS} < V_{TS_DISABLE}$	30	50	70	mV
REGN REGULATOR						
V_{REGN_REG}	REGN regulator voltage	$V_{VCC} > 7V$	5.2	5.4	5.6	V
I_{REGN_LIM}	REGN current limit	$V_{REGN} = 0V, V_{VCC} > 7V$		100		mA
INTERNAL PWM						
F_{SW_CHG}	PWM Switching Frequency	Measure at LX	900	1000	1100	kHz
SAFETY TIMER						
$T_{PRE-CHARGE}$	Pre-charge timer		4822	5400	6048	Sec
$T_{TAPER-CHARGE}$	Taper-charge timer		4822	5400	6048	Sec
DC/DC STAGE						
V_I	Input voltage range	V_{BAT} input voltage	2.8		5.5	V
V_{OUT_SHORT}	Output short threshold	V_{OUT} falling, Boost off		3.8		V
V_{BAT_UVLO}	Battery low voltage lockout	V_{BAT} voltage decreasing, Boost off	2.75	2.8	2.85	V
f_{SW}	Oscillator frequency		550	600	650	kHz
I_{STDBY}	Standby current	$V_{BAT} = 4.2V$, Boost off		40	60	μA
QC 2.0 Mode						
V_{OUT}	Output voltage	$V_{VOST1}/V_{VOST2}=FLT/FLT$ Measure at V_{OUT}		5.10		V
		$V_{VOST1}/V_{VOST2}=Lo/FLT$, Measure at V_{OUT}		9.0		V
		$V_{VOST1}/V_{VOST2}=Lo/Lo$, Measure at V_{OUT}		12.0		V
	Output regulation accuracy	$T_J = -20^{\circ}C$ to $85^{\circ}C$	-2%		2%	
V_{5VOUT_VO}	Output overvoltage threshold	V_{OUT} rising, NDRV off		6.0		V
$V_{5VOUT_VO_HYS}$	Output overvoltage threshold	V_{OUT} falling, NDRV on		5.82		V
$t_{5VOUT_OV_DEG}$	Output overvoltage deglitch	$V_{OUT} > V_{OUT_VO}$ to NDRV off		2		ms
V_{5VOUT_UV}	Output under-voltage threshold	V_{OUT} falling, NDRV off		4.25		V
V_{9VOUT_UV}	Output under-voltage threshold	V_{OUT} falling, back to 5V		7.8		V
V_{12VOUT_UV}	Output under-voltage threshold	V_{OUT} falling, back to 5V		10.5		V
$t_{VOUT_UV_DEG}$	Output under-voltage deglitch	$V_{OUT} < V_{OUT_UV}$ to NDRV off		4		ms



PARAMETERS		TEST CONDITIONS	MIN	TYP	MAX	UNITS
V _{BAT-VSNS1}	Battery output current limit sense voltage @ V _{BAT} =3V	I _{OST} =FLT, RSNS=10mΩ		87.5		mV
		I _{OST} =Lo, RSNS=10mΩ		75		mV
		I _{OST} =Hi, RSNS=10mΩ		100		mV
	Battery output "current limit" formula	4.20V > V _{BAT} > V _{BAT-UVLO} ;	V _{BAT-VSNS1} / RSNS			A
External Resistor Feedback Mode (V_{VOST1}/V_{VOST2}= FLT/Lo)						
V _{OUT-FBREG}	Output voltage range	V _{VOST1} /V _{VOST2} = FLT/Lo	4.5		13.5	V
V _{BT-FB}	Feedback voltage	V _{VOST1} /V _{VOST2} = FLT/Lo, Measure at BT_FB	1.245	1.265	1.285	V
V _{VOUT-UV}	Output under-voltage threshold	V _{OUT} falling, NDRV off		4.25		V
t _{VOUT-UV-DEG}	Output under-voltage deglitch	V _{OUT} < V _{OUT-UV} to NDRV off		4		ms
V _{BAT-VSNS2}	Battery output current limit sense voltage @ V _{BAT} =3V	I _{OST} =FLT, RSNS=10mΩ		75		mV
		I _{OST} =Lo, RSNS=10mΩ		50		mV
		I _{OST} =Hi, RSNS=10mΩ		100		mV
	Battery output "current limit" formula	4.20V > V _{BAT} > V _{BAT-UVLO} ;	V _{BAT-VSNS2} / RSNS			A
CONTROL STAGE						
V _{NDRV-OL}	NDRV output low voltage				0.1	V
V _{NDRV-HI}	NDRV output high voltage		V _{OUT} -0.1			V
V _{IL}	BT_EN logic low threshold		0.4			V
V _{IH}	BT_EN logic high threshold				1.4	V
t _{BT-EN-DEG}	BT_EN logic low deglitch time			15	50	mS
V _{VOST1,2-FLT}	VOST1,2 Floating Output Voltage			0.8		V
V _{VOST1,2-IL}	VOST1,2 logic low threshold		0.4			V
V _{VOST1,2-IH}	VOST1,2 logic low threshold				1.4	V



VOST1,2 Control (0: floating, 1: pull down)

1. VOST1 & VOST2 set boost converter as a typical 5V output or enter QC2.0 class-A mode which can fully compatible with V1, V2 logic state of CHY-100 charger interface IC.
2. For a QC2.0 design, VAS5289 uses internal divider and skips external feedback network to simplify the design and BOM.
3. During QC2.0 9V/12V operation, any overload condition happened will exit the QC mode and boost converter automatically return to 5V output mode, regardless of continuing QC instruction from interface IC. Disconnect load to restart a new D+/D- handshaking or do BT_EN toggle to reboot boost converter to back to QC out mode.
4. For considering traditional ext. feedback network regulation or supporting other interface IC control, keep VOST1 floating and pull down VOST2 to enable BT_EN pin function for a feedback input with a 1.265V voltage.
5. To avoid an accidental large peak current, an internal cycle-by-cycle current limit is adopted. The low-side switch is turned off immediately as soon as the switch current touches the limit. The peak switch current limit also help to control total input power of Boost DC/DC converter, can be set by Rsns resistor and status of IOST pin. The relationship between the power limit ratio verses IOST and “OUTPUT MODE” are shown as below table, see “EC table” for detail threshold of current limit.

VOST1	VOST2	MODE	Power Limit Ratio		
			IOST=Lo	IOST=FLT	IOST=FLT
0	0	5V	0.75	1.00	1.25
0	1	Ext. Resistor Feedback	0.75	1.00	1.25
1	0	9V (QC2.0)	1	1.125	1.25
1	1	12V(QC2.0)	1	1.125	1.25

BT_EN Control

1. BT_EN is the enable logic input. Logic high level enables the device. Logic low level disables the device and turns it into shutdown mode.
2. The logic low at BT_EN can reset VOST1 and VOST2 state and immediately stop step-up switching and NDRV goes low to disconnect load.



Application Information

◆ Charge Management

1. Typical Operation Theory

The charger of VAS5289 is optimized for charging 1-cell Li-ion or Li-polymer batteries. It charges a battery with constant current (CC) and constant voltage (CV) profile. In CV mode, if charge current reaches 1/10 constant current threshold, STAT goes Hi-Z to indicate charge full. The typical charge profile is illustrated as below.

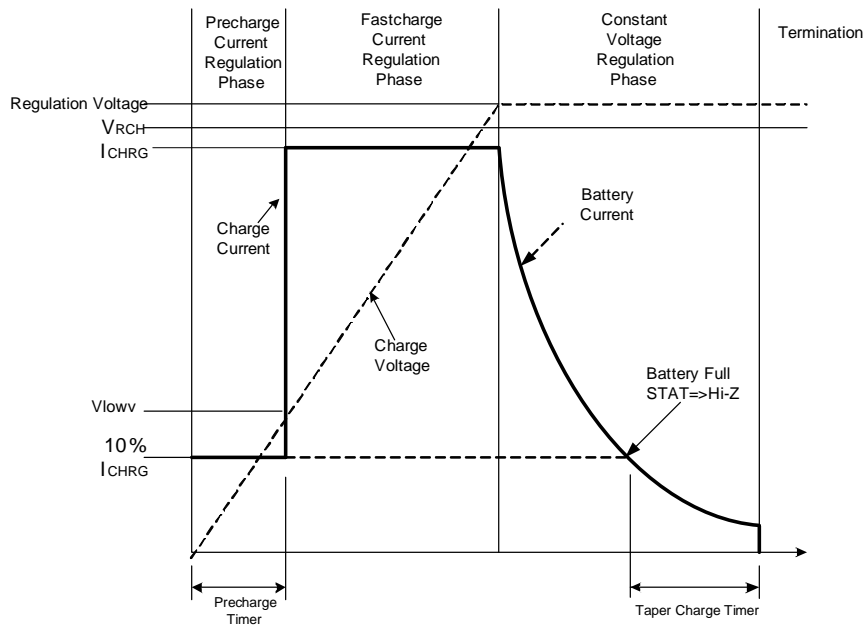

Figure 4. Typical Charging Profile

2. Battery Voltage Regulation

The VAS5289 offers a high accuracy voltage regulator for the charging voltage. Battery regulation voltage could be adjusted by setting BVST level for 4.2V, 4.30V and 4.35V selection, see “Electrical Characteristics Table” for the detail.

3. Battery Current Regulation

The ISET input sets the maximum charging current. The ISET level selects charge current sense voltage as 18mV, 22.5mV or 27mV, see “Electrical Characteristics Table” for the detail. The equation for charge current is:

$$I_{CHG} = \frac{V_{VSNS-VBAT}}{R_{SNS}}$$

Give a 10mΩ RSNS and set ISET floating for a 22.5mV V_{VSNS-VBAT} will be able to get 2.25A charge current, for instance. Considering high voltage input for QC in application, VAS5289 detection voltage at VCC pin, once VCC



voltage is above 7.5V, then device adjust the charge current to 1.5 times to the present value to optimize the charging rate.

4. Battery Pre-charge Current Regulation

If the battery voltage is below the V_{BSHORT} threshold, the switching loop stop and the VAS5289 applies a weak 15mA charge current to the battery. This weak charge feature is intended to revive deeply discharged cells. If the battery voltage is greater than V_{BSHORT} and less than V_{LOWV} threshold, the battery will be charged by pre-charge cycle with a 1/10 of fast charge current. If battery is not reached V_{LOWV} within 90 minutes of initiating pre-charge, the charger turns off and a FAULT is indicated on the status pins.

5. Charge Termination

The charger monitors the charging current during the voltage regulation phase. Termination is detected when the charge taper down to 1/10 of the fast charge rate.

6. Input Voltage Regulation

The input voltage can be limited in order to avoid overloading of DC adapter or USB power source, for normal 5V input, when the voltage on VIN pin drops and hits the threshold voltage of 4.6V, the charging current will be decreased and input voltage will be clamped to this value. In QC in mode with 9V/12V input, the DPM voltage will be adjusted to 8.3V.

7. Re-Charge

A new charge cycle is initiated when one of the following conditions occurs:

- The battery voltage falls below the recharge threshold
- A power-on-reset (POR) event occurs

8. Timers

As a safety backup, the charger also provides an internal fixed 90 minutes pre-charge safety timer. And fixed 90minutes taper charge timer for additional charge capacity, it start once termination is happened.

9. Soft-Start Charger Current

The charger automatically soft-starts the charger regulation current every time the charger goes into fast-charge to ensure there is no overshoot or stress on the output capacitors or the power converter.

10. Temperature Qualification

The TS pin output a zero TC current to bias a negative temperature coefficient thermistor (TS) which connect to AGND. The controller continuously monitors battery temperature by measuring the voltage between the TS pin and AGND, it compares this voltage against its internal thresholds to determine if charging is allowed. To initiate a charge cycle, the battery temperature must be within the VLTF to VHTEF thresholds. If battery temperature is outside of this range, the controller suspends charge and waits until the battery temperature is within the VLTF to VHTEF range. The controller suspends charge by turning off the PWM MOSFETs. In the Boost mode, battery cell temperature qualification still works with a different VHTEF threshold, typically more 10 degree C range compare to charge cycle. A 10K TS with B-Constant around 3950k is recommended for application.



◆ Boost Converter

1. Typical Operation Theory

The VAS5289 integrates a boost converter powered by a one-cell Li-Ion or Li-polymer battery. The converter provides high efficient power conversion with two external low on resistance NMOSFETs and is capable of output 5V to 12.6V voltage and delivering power up to 25W. The implemented boost converter is based on a fixed frequency, in moderate to heavy load condition, the device works in the pulse width modulation (PWM) mode, in light load condition, the device works in the pulse frequency modulation (PFM) mode to improve the efficiency.

2. Soft Start

The boost automatically soft-starts the switching current to load to ensure there is no overshoot or inrush stress on the output capacitors, the boost switch current limit is set to 50% of its normal value to avoid high peak current at battery during soft-start period. When the output voltage is reached, the voltage regulator takes control and switch current limit is set back to 100%.

3. Power Limit

The maximum peak current in the boost switch is set by the resistance of R_{SNS} and sense voltage $V_{VBAT-VSNS}$ that according to IOST level, the unique input and output voltage compensation peak current detection help to control maximum IOUT in constant current mode regardless of input/output voltage variation if it reached to maximum tripped value. The sense voltage $V_{VBAT-VSNS}$ limit the boost input current at 3.0V VBAT, with the gradual increase in VBAT voltage, current limit will be gradually reduced, in order to achieve the first stage input constant power control, the controller continuously monitors VOUT voltage add compensation to sense current to achieve the second stage output constant current control. In other words, with $V_{VBAT-VSNS}$ and R_{SNS} decide the current limit if VBAT equal to 3.0V, consider converting efficiency can get output current limit tripped point. With this setup, the VBAT and VOUT voltage vary will change current limit very small, can be regarded as a constant current mode.

4. Over-load & Short Protection

If the output current reaches the over-current point, output current begins to start limiting and then voltage fall down, when the voltage dropped below 3.8V, NDRV shut down immediately and disconnect the output, but boost does not latch-off, but if output consistently below 4.25V for more than 2ms, the boost circuit locked and needed to be restart.

In QC2.0 mode, if over-load condition makes output voltage drop below the threshold, boost will stop QC mode and regulate output back to 5V typical.

5. Over-voltage protection

In 5V operation, the controller continuously monitors the output voltage, if the voltage is higher than 6.0V, NDRV disconnect the load immediately to protect the device. In QC 2.0 mode, 6.0V protection will be blocked.

6. Low Battery & battery under-voltage lockout

If the boost converter input voltage dropped lower than 3.10V, then no matter what mode had set by VOST1,2, devices will be forced return to 5V mode. Once voltage at VBAT pin drop to 2.8V, VAS5289 will do latch-off protection, this protection requires input DC charging is performed and can be released.



Tape and Reel Information

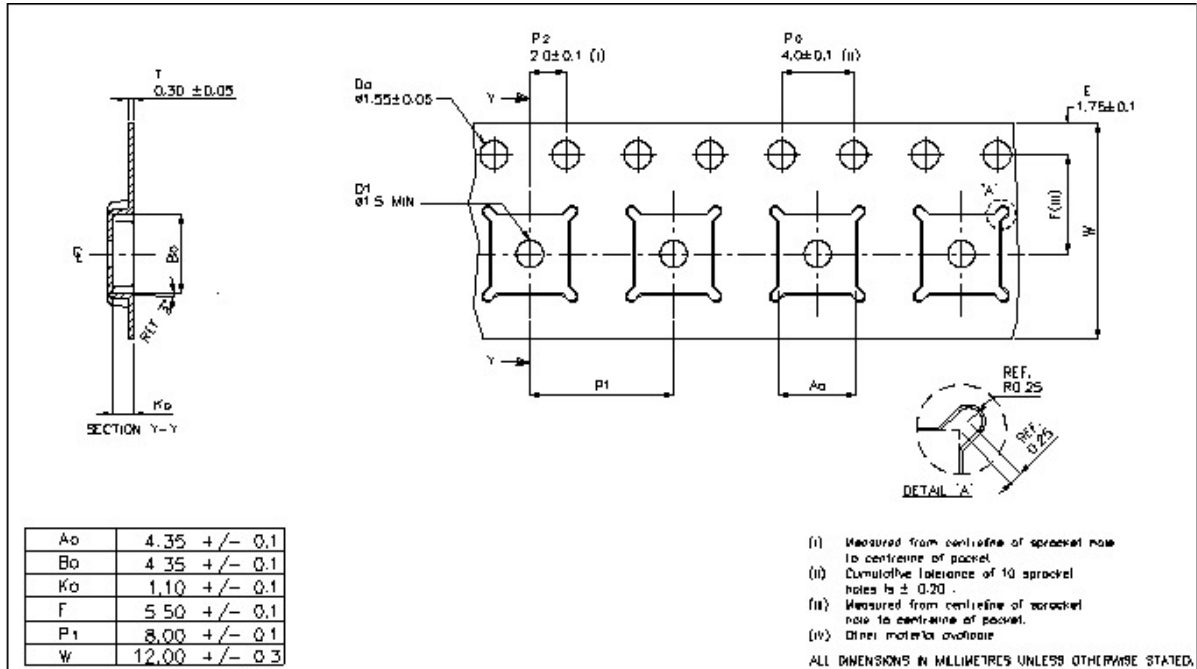

Package Information

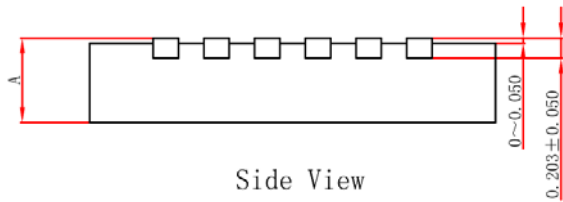
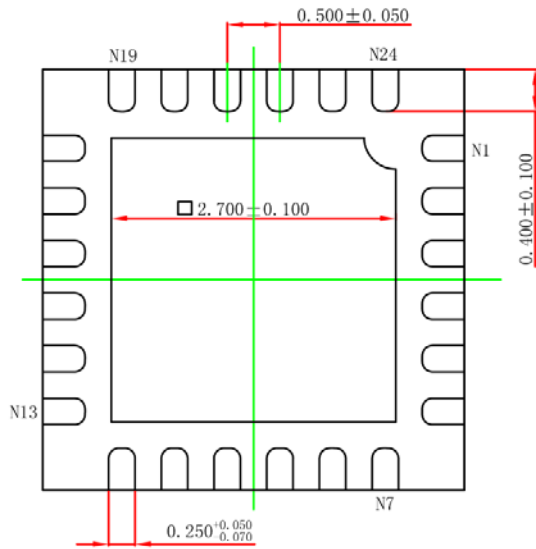
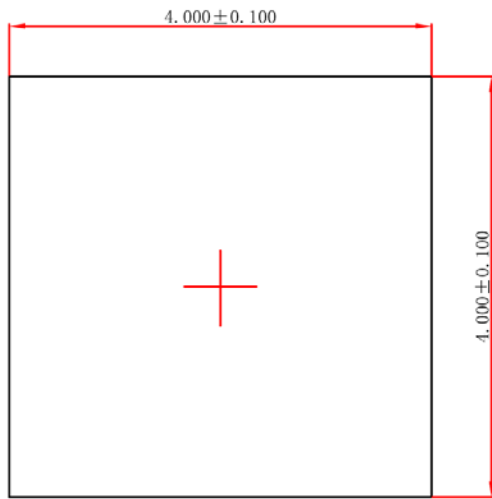

	MIN.	NORM.	MAX.
A	0.700	0.750	0.800
	0.800	0.850	0.900

Classification Reflow Profiles

Profile Feature	Pb-Free Assembly
Preheat & Soak Temperature min (T_{smin}) Temperature max (T_{smax})	150°C
Time (T_{smin} to T_{smax}) (ts)	200°C 60-120 seconds
Average ramp-up rate (T_{smax} to T_p)	3°C/second max.
Liquidous temperature (TL)	217°C
Time at liquidous (tL)	60-150 seconds
Peak package body temperature (T_p)*	Max 260°C
Time (tp)** within 5°C of the specified classification temperature (T_c)	Max 30 seconds
Average ramp-down rate (T_p to T_{smax})	6°C/second max.
Time 25°C to peak temperature	8 minutes max.

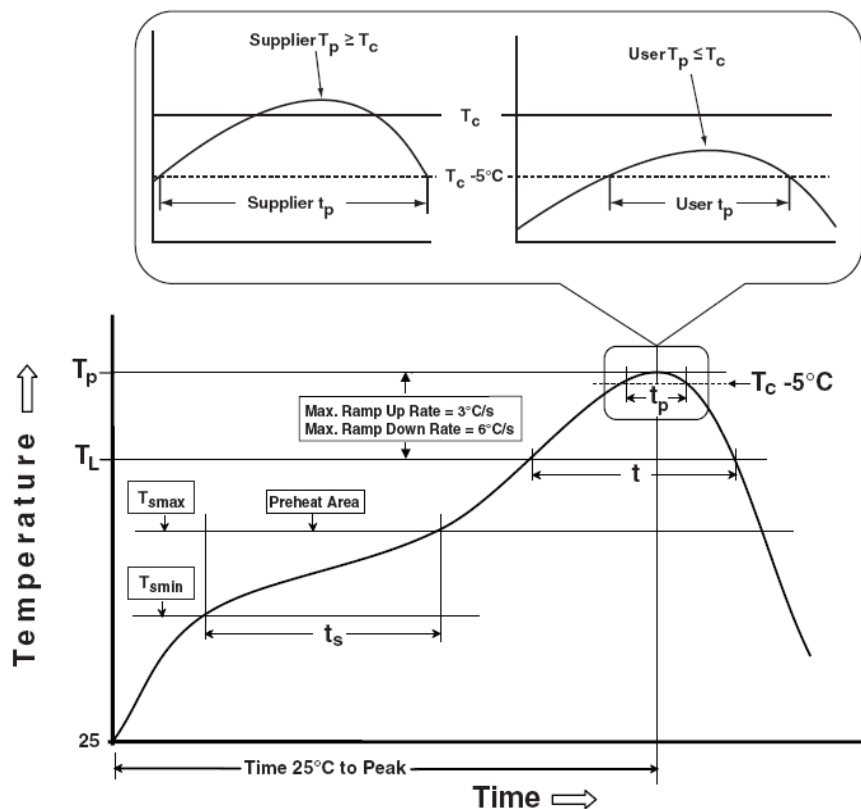

Figure 21. Classification Profile

CAUTION

Storage Conditions

1) This product should be used within 12 months after delivered. Store in manufacturer's package keeping the seal of aluminum coated baggage or tightly re-closed box with the following conditions.

[Temperature:8°C ...30°C ,Humidity:30%...70% R.H.]

2) Keep the seal of aluminum coated baggage immediately before usage.

3) After breaking the seal of aluminum coated baggage, this product should be used within 1 week on the following conditions.

[Temperature:≤30°C, Humidity: ≤60% R.H.]